

AHS-Series Dimensions

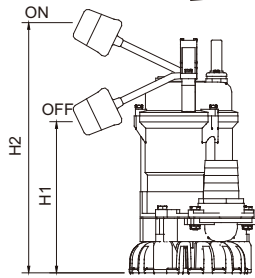

Dimensions (mm)

Type	A	A1	A2	H	H1	H2
AHS-05	243	94	117	352	84	200
AHS-05A	243	94	117	352	200	400
AHS-10	279	94	133	377	84	225
AHS-10A	279	94	133	377	225	425
AHS-20	313	107	155	464	94	308
AHS-20A	313	107	155	464	294	494

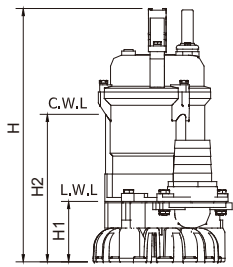
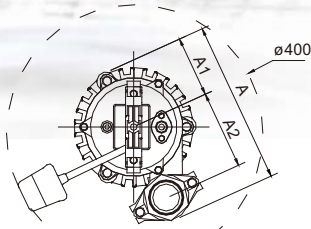
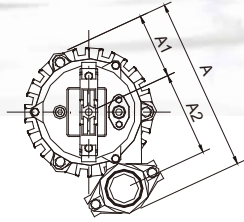

APEC PUMP ENTERPRISE CORP.

3F., No.394, Sec.2 Mingzhi Rd., Taishan Dist., New Taipei City 243, Taiwan.
 TEL: +886-2-29034567 Fax: +886-2-29064567

18221-SHA-170313



AHS SERIES 60HZ

Submersible Dewatering Pump



www.apecpump.com

AHS SERIES 60HZ

Submersible Dewatering Pump

Feature

- / High abrasive resistance resin Vortex impeller
- / Double mechanical seal / Designed Agitator
- / Auto reset thermal protector / Non air locking
- / Auto version for small pit usage

Application

- / Residential, commercial, industrial dewatering and site drainage
- / Decorative waterfalls and fountains
- / Raw water supply from lakes or rivers
- / Sediment removal from small sumps or basins

Specifications

Liquid Temperature		0~40°C (32~104°F)
Submersible depth		10M
Motor Part	Frequency	60Hz
	Pole	2 Pole
	Type	Dry Type
	Insulation	Class B
	Protection	IP 68
Pump Part	Protector	Auto-cut
	Bearing	Ball Type
	Mechanical seal	Dual. Mechanical Seal
	Impeller	Semi-Open

Performance Curve

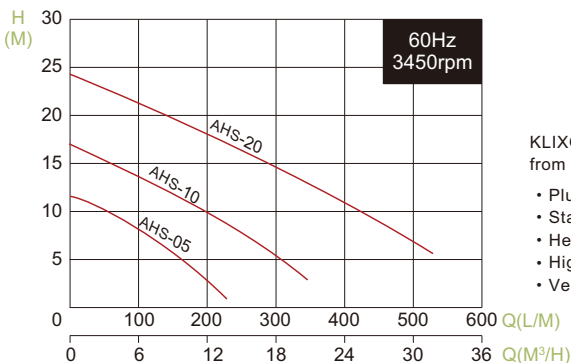

Steel coated with thermoplastic polyester elastomer



Agitator

KLIXON



1PH Protector (Thermal)



1PH Protector (optional) (overheat & overload)



3PH Protector (overheat, overload)

KLIXON protector provides protection against overheating from all running and stalled rotor conditions including:

- Plugging duty
- Stalling or failure to start
- Heavy overloads
- High ambient
- Ventilation failures

Parts and Material List

No	Part	Material
1	Cable	H07RN-F /SJTW/STOW
2	Handle	Nylon 6
3	Motor Cover	ADC 12
4	Bracket	Steel
5	Motor Housing + Stator	ADC12+Steel
6	Shaft with Rotor	SUS 410
7	Oil Chamber	0.5~1HP : Cast Iron 2HP : Aluminum
8	Mech. Seal	Upper : CA/CE Lower : SIC/SIC
11	Impeller	Hytrel
12	Pump Casing	Cast Iron
15-1	Upper Bearing	NTN
15-2	Lower Bearing	NTN
16	Strainer	PVC
28	Agitator	SMF5030

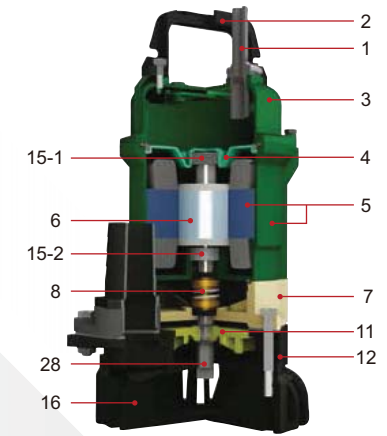

Data Chart

Type	Output		Discharge	F.L.A.				Rated		Maximum		Cable	Free Passage	Weight
	HP	KW		1ø 115V	1ø 230V	3ø 220V	3ø 460V	Head m	Cap. LPM	Head m	Cap. LPM			
AHS-05	0.5	0.37	2"	7	3.5	1.6	1	8	110	12	240	5	6	12
AHS-05A	0.5	0.37	2"	7	3.5	1.6	1	8	110	12	240	5	6	12.5
AHS-10	1	0.75	2"(3")	12	6	3.4	2	10	200	18	350	5	6	15
AHS-10A	1	0.75	2"(3")	12	6	3.4	2	10	200	18	350	5	6	15.5
AHS-20	2	1.5	2"(3")	28	13	6.7	3.5	15	240	24	520	5	6	19
AHS-20A	2	1.5	2"(3")	28	13	6.7	3.5	15	240	24	520	5	6	19.5

» A identifies black float switch.

» All single-phase and three-phase pumps can be equipped with float switch upon request.

» Key float switch are available to choose.



Optional: Suction Plate

The bottom strainer is interchangeable with a bottom suction plate. With the optional suction plate, the pump can continue pumping the water level down to 3mm.

